



Hydraulic & Offshore Supplies

t: +44(0)191 549 7335

e: hose@hos.co.uk

w: www.hos.co.uk

Parker Fitting Assembly



Table of contents

Port connections MF4

Port connections BSPPF5

Port connections UNF.....F6

Port connections TAPER.....F7

Adjustable fittings with locknut.....F8

EO swivelsF9

Triple-Lok® / O-Lok® swivelsF10

FlangesF11

Replacement / DA.....F12

Tube bendingF13

Tube line fabrication guideF14



Port connections

Assembly of metric straight port connections



- Metric Thread
DIN ISO 6149-2/3
ISO 9974-2/3
DIN 3852 T1/T2

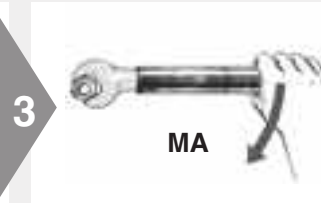

- ⚠ Threads of stainless steel fittings must be lubricated
- EO-NIROMONT is a special high-performance lubricant for stainless steel fittings
- Screw in until handtight
- Then tighten according to chart

Assembly torques for metric threads

Product	Tube O.D.	Thread size T mm	Straight male stud fittings with port tapping					Non-return valves RHV/RHZ Form E with ED sealing Nm	EO Banjo fittings		Adjustable ends		Blanking plugs	
			Form A for sealing washer Nm	Form B with face Nm	Form E with ED sealing Nm	Form F with O-ring sealing Nm	O-ring with sealing and retaining ring		WH/TH Nm	SWVE Nm	O-ring and retaining ring Nm	O-ring Nm	VSTI-ED Form E mit ED sealing Nm	VSTI-OR Form F with O-ring sealing Nm
EO L Triple-Lok®	6	M10 × 1.0	9	18	18	15	18	18	18	18	18	15	12	20
	8	M12 × 1.5	20	30	25	25	35	25	45	35	35	25	25	
	10	M14 × 1.5	35	45	45	35	45	35	55	50	45	35	35	
	12	M16 × 1.5	45	65	55	40	55	50	80	60	55	40	50	
	15	M18 × 1.5	55	80	70	45	70	70	100	80	70	45	65	
	18	M22 × 1.5	65	140	125	60	160	125	140	120	180	60	90	
	22	M26 × 1.5	90	190	180	100*	250	145	320	130	180	100	135	
	28	M33 × 2.0	150	340	310	160	310	210	360		310	160	225	
	35	M42 × 2.0	240	500	450	210	450	360	540		450	210	360	
	42	M48 × 2.0	290	630	540	260	540	540	700		600	260	360	
EO S O-Lok®	6	M12 × 1.5	20	35	40	35		35	45	35	35	35		35
	8	M14 × 1.5	35	55	40	45		45	55	50	60	45		45
	10	M16 × 1.5	45	70	70	55		55	80	60	95	55		55
	12	M18 × 1.5	55	110	90	70		70	100	80	120	90		70
	14	M20 × 1.5	55	150	125	80		100	125	110			80	80
	16	M22 × 1.5	65	170	135	100		125	135	120	190	100		100
	20	M27 × 2.0	90	270	180	170		135	320	135	190	170		170
	25	M33 × 2.0	150	410	310	310		210	360		500	310		310
	30	M42 × 2.0	240	540	450	330		360	540		600	330		330
	38	M48 × 2.0	290	700	540	420		540	700		600	420		420

Tolerance of tightening torques listed in above table: +10 %
 Note: Lubricate stud with hydraulic oil before screwing in!
 Tightening torques relate to counterpart made of steel.
 *Thread M27×2

Port connections



Assembly of BSPP straight port connections

- BSPP Thread G
ISO 1179-1
DIN 3852 T2



⚠ Threads of stainless steel fittings must be lubricated

- EO-NIROMONT is a special high-performance lubricant for stainless steel fittings

● Screw in until handtight

● Then tighten according to chart

Assembly torques for BSPP threads

Product	Tube O.D.	Thread size T Inch	Straight male stud fittings with port tapping				Non-return valves RHV/RHZ Form E with ED-sealing	EO Banjo fittings		Adjustable ends O-ring and retaining-ring Nm	Blanking plugs VSTI-ED Form E with ED-sealing Nm
			Form A for sealing washer Nm	Form B with cutting-face Nm	Form E with ED-sealing Nm	with O-ring sealing and retaining-ring		WH/TH Nm	SWVE Nm		
EO L Triple-Lok®	6	G 1/8A	9	18	18	18	18	18	18	18	13
	8	G 1/4A	35	35	35	35	35	45	40	35	30
	10	G 1/4A	35	35	35	35	35	45	40	35	
	12	G 3/8A	45	70	70	70	50	70	65	70	60
	15	G 1/2A	65	140	90	90	85	120	90	110	80
	18	G 1/2A	65	100	90	90	65	120	90	110	
	22	G 3/4A	90	180	180	180	140	230	125	180	140
	28	G 1A	150	330	310	310	190	320		310	200
	35	G 1 1/4A	240	540	450	450	360	540		450	400
	42	G 1 1/2A	290	630	540	540	540	700		540	450
EO S O-Lok®	6	G 1/8A								25	
	6	G 1/4A	35	55	40		45	45	40	55	
	8	G 1/4A	35	55	40		45	45	40	55	
	10	G 3/8A	45	90	80		60	70	65	90	
	12	G 3/8A	45	90	80		60	70	65	90	
	14	G 1/2A	65	150	115		145	120	90	110	
	16	G 1/2A	65	130	115		100	120	90	110	
	20	G 3/4A	90	270	180		145	230	125	115	
	25	G 1A	150	340	310		260	320		420	
	30	G 1 1/4A	240	540	450		360	540		550	
38	G 1 1/2A	290	700	540		540	700		600		

Tolerance of tightening torques listed in above table: +10%
 Note: Lubricate stud with hydraulic oil before screwing in!
 Tightening torques relate to counterpart made of steel.

F

Port connections

Assembly of SAE straight port connections

- UN/UNF thread
ISO 11926-2/3

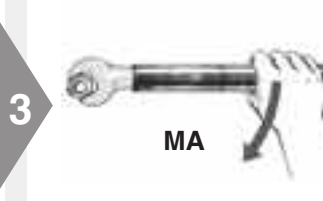
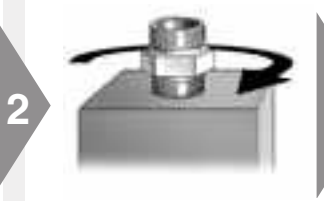

- ⚠ Threads of stainless steel fittings must be lubricated
- EO-NIROMONT is a special high-performance lubricant for stainless steel fittings

- Screw in until handtight

- Then tighten according to chart

Assembly torques for UNF threads

Product	Thread size T ISO 11296	Series	
		EO / Triple-Lok® and O-Lok®	
Series	inch	Assembly torque non-adjustable end Nm	Assembly torque adjustable end Nm
EO L Triple-Lok®	7/16-20 UN(F)	23	18
	1/2-20 UN(F)	28	28
	9/16-18 UN(F)	34	34
	3/4-16 UN(F)	60	55
	7/8-14 UN(F)	115	80
	1.1/16-12 UN(F)	140	100
	1.5/16-12 UN(F)	210	150
	1.5/8-12 UN(F)	290	290
EO S O-Lok®	1.7/8-12 UN(F)	325	325
	7/16-20 UN(F)	20	20
	1/2-20 UN(F)	40	40
	9/16-18 UN(F)	46	46
	3/4-16 UN(F)	80	80
	7/8-14 UN(F)	135	135
	1.1/16-12 UN(F)	185	185
	1.5/16-12 UN(F)	270	270
1.5/8-12 UN(F)	340	340	
1.7/8-12 UN(F)	415	415	

Tolerance of tightening torques listed in above table: + 10 %
 Note: Lubricate stud with hydraulic oil before screwing in!
 Tightening torques relate to counterpart made of steel.

Port connections

Assembly of tapered thread port connections



- NPT / NPTF thread
ANSI / ASME B 1.20.1 – 1983

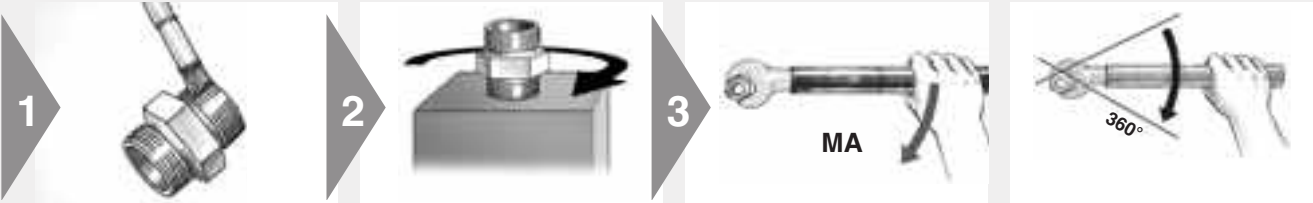

F

- ⚠ Threads of stainless steel fittings must be lubricated
- EO-NIROMONT is a special high-performance lubricant for stainless steel fittings
- Screw in until handtight
- Then tighten according to chart
- one flat = 360°

Tightening of NPT / NPTF thread

Size	Thread T NPT/F	Assembly TFFT Turns
4	1/8-27 NPT/F	2.0–3.0
6	1/4-18 NPT/F	2.0–3.0
8	3/8-18 NPT/F	2.0–3.0
10	1/2-14 NPT/F	2.0–3.0
12	3/4-14 NPT/F	2.0–3.0
16	1-11 1/2 NPT/F	1.5–2.5
20	1 1/4-11 1/2 NPT/F	1.5–2.5
24	1 1/2-11 1/2 NPT/F	1.5–2.5

In the EO fitting range only **NPT** threads are manufactured.
In the **Triple-Lok®** and **O-Lok®** fitting range for **steel** **NPTF** threads are used, and NPT for stainless steel components.

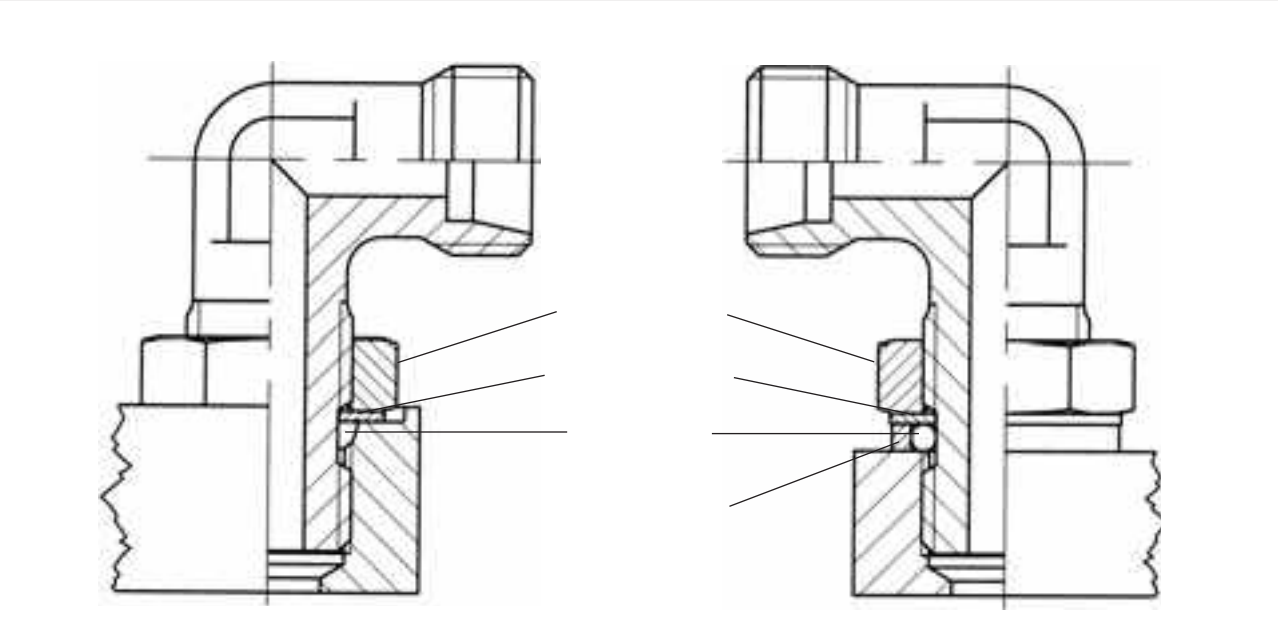

EO swivels



Assembly of EO swivel nut fittings

(e.g. EW, ET, EL, EGE, RED, VKA, SKA)

- Final assembly of swivel nut fittings must be made in appropriate fittings



- 1
- ⚠ Threads of stainless steel fittings must be lubricated
 - EO-NIROMONT is a special high-performance lubricant for stainless steel fittings



- 2
- Screw on nut by hand until handtight

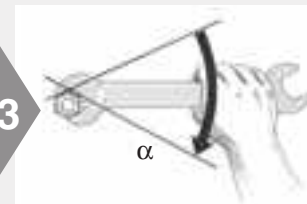

- 3
- ⚠ Then tighten fitting firmly by 1/4 turn (1 1/2 flats)



Final assembly of factory pre-assembled EO-standpipe fittings

(e.g. EVW, EVT, EVL, EVGE, KOR)

- For all fittings delivered pre-assembled from the factory the final assembly is performed in the appropriate fitting body



- 1
- ⚠ Threads of stainless steel fittings must be lubricated
 - EO-NIROMONT is a special high-performance lubricant for stainless steel fittings



- 2
- Assemble fitting until wrench tight (without spanner extension)
 - ⚠ Mark position of nut

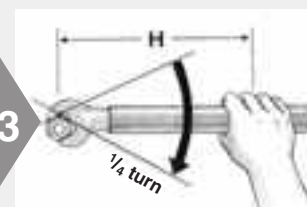

- 3
- ⚠ Then tighten fitting firmly by 1/4 turn (1 1/2 flats)
 - ⚠ Recommended to use spanner extension for sizes over 20 mm O.D. (see chart)

Spanner length

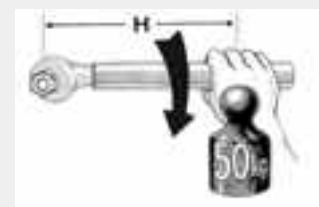

Size	Spanner length H [mm]
18-L 16-S	300
22-L 20-S	400
28-L 25-S	500
35-L 30-S	900
42-L 35-S	1200
50-L 42-S	1500

Triple-Lok® / O-Lok® swivels



Assembly of Triple-Lok® and O-Lok® swivel nut fittings

e.g.: Triple-Lok®: C6MX, V6MX, R6MX, S6MX, BBMTX
 O-Lok®: C6MLO, V6MLO, S6MLO, R6MLO, A0EL6

- Final assembly of swivel nut fittings must be made in appropriate fittings

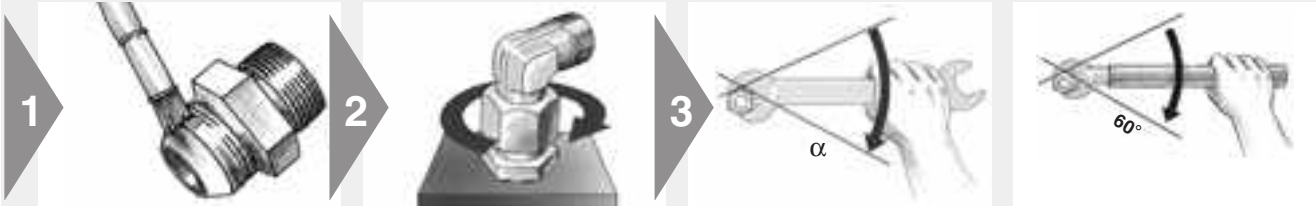

- ⚠ Threads of stainless steel fittings must be lubricated
- EO-NIROMONT is a special high-performance lubricant for stainless steel fittings

- Screw on nut by hand until handtight

- Then tighten according to chart

- one flat = 60°

Assembly torques for O-Lok® and Triple-Lok® swivel nut fittings

O-Lok®

Size	Metric tube mm	Inch tube inch	Thread UN/UNF	Nm	FFWR
4	6	1/4"	9/16-18	25	1/2
6	8	5/16"	1.1/16-16	40	1/2
6	10	5/16"	1.1/16-16	55	1/2
8	12	1/2"	1.3/16-16	55	1/2
10	14, 15, 16	5/8"	1-14	115	1/2
12	18, 20	3/4"	1.3/16-12	130	1/2
16	22, 25	1"	1.7/16-12	150	1/2
20	28, 30, 32	1.1/4"	1.11/16-12	190	1/2
24	35, 38	1.1/2"	2-12	245	1/2
32	50	2"	2.1/2-12	490	1/2

Triple-Lok®

Size	Metric tube mm	Inch tube inch	Thread UN/UNF	Nm	FFFT
4	6	1/4"	7/17-20	15	2
5	8	5/16"	1/2-20	20	2
6	10	3/8"	9/16-18	45	1 1/4
8	12	1/2"	3/4-16	60	1
10	14, 15, 16	5/8"	7/8-14	75	1
12	18, 20	3/4"	1.1/16-12	100	1
16	22, 25	7/8"	1.5/16-12	150	1
20	30, 32	1.1/4"	1.5/8-12	180	1
24	38	1.1/2"	1.7/8-12	200	1
28	42		2.1/4-12	220	1
32		2"	2.1/2-12	250	1

Assembly torques shown in chart are for **non-lubricated carbon steel zinc plated components**.
 For stainless steel fittings, lubricate all mating surfaces and tighten to upper end of torque tolerance.
 Recommended assembly torques are for connections consisting of all Parker manufactured components.

Flanges



Assembly of flanges

- SAE flange adapters
- SAE 4 bolt flanges
- Gear pump flanges
- CETOP square flanges

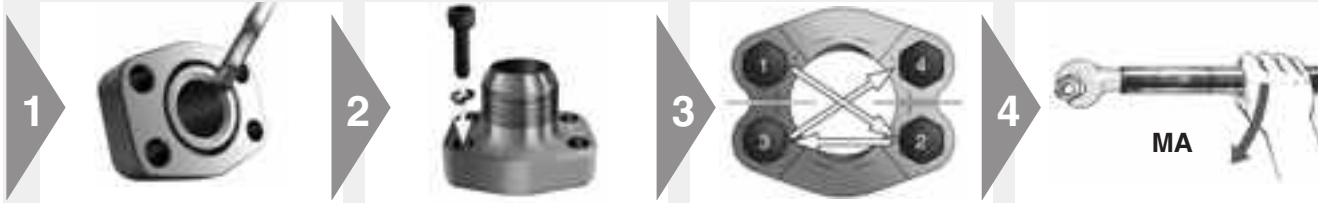

- Make sure sealing surfaces are free of burrs, nicks, scratches or any contamination
- Lubricate the O-ring with system fluid or compatible lubricant
- Position flange and clamp halves
- Place lock washers on bolts and bolt through clamp halves
- Hand tighten bolts
- Torque bolts in diagonal sequence in small increments to the appropriate torque level listed in chart
- Tighten bolts according to chart

3000 PSI Series (Code 61) Flange recommend screw torque

Dash size	Flange size	Inch screws (J518)	Torque Nm ¹⁾	Metric screws (ISO 6162)	Torque Nm ¹⁾
13	1/2"	5/16-18	24	M8	24
19	3/4"	3/8-16	43	M10	50
25	1"	3/8-16	43	M10	50
32	1.1/4"	7/16-14	70	M10	50
38	1.1/2"	1/2-13	105	M12	92
51	2"	1/2-13	105	M12	92
64	2.1/2"	1/2-13	105	M12	92
76	3"	5/8-11	210	M16	210
89	3.1/2"	5/8-11	210	M16	210
102	4"	5/8-11	210	M16	210
127	5"	5/8-11	210	M16	210

6000 PSI Series (Code 62) Flange recommend screw torque

Dash size	Flange size	Inch screws (J518)	Torque Nm ¹⁾	Metric screws (ISO 6162)	Torque Nm ¹⁾
13	1/2"	5/16-18	24	M8	24
19	3/4"	3/8-16	43	M10	50
25	1"	7/16-14	70	M12	92
32	1.1/4"	1/2-13	105	M12	130
38	1.1/2"	5/8-11	210	M16	210
51	2"	3/4-10	360	M20	400

Hydraulic Flange recommend screw torque

Socket screw bolt circle (LK)	Socket head cap screws	Tightening torques Nm ¹⁾
LK30	M6	10
LK35	M6	10
LK40	M6	10
LK51	M10	49
LK55	M8	25
LK56	M10	49
LK62	M10	49
LK72.5	M12	85

1) Tolerances: max. 10 %
min. 0 %

F

Replacement of an EO Bite type connection



Distance piece adapter DA

- EO distance piece adapters allow replacement of bite type connections on existing pipework easily or retrofitting using EO-2
- The existing tubes can be re-used

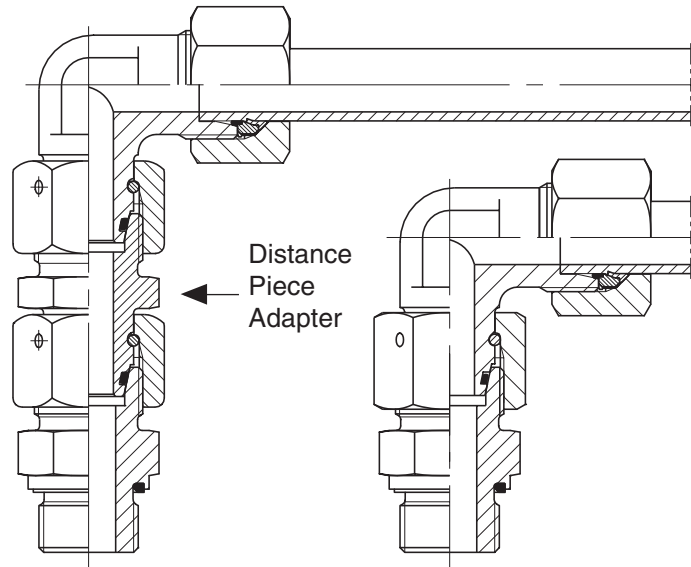

- Use as an extension for stacked assemblies

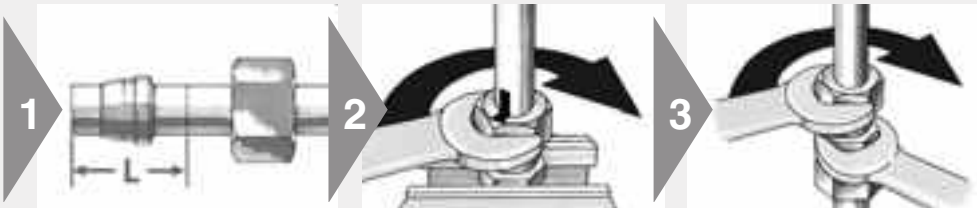

- 1**
- Cut length L off tube-end (see "DA" chapter I)
 - Scrap obsolete nut

- 2**
- Assemble new EO-2 functional nut or EO PSR/DPR and nut

- 3**
- Thread on
 - Then tighten distance piece adapter onto tube-end

Tube bending

Instructions for EO hand bending equipment

- For on-site piping jobs
- Not for mass production

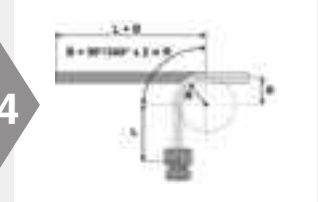
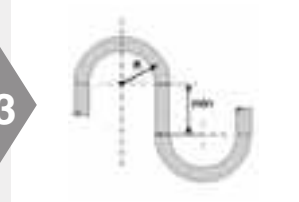
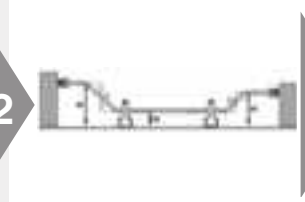

- ⚠ Think the whole process through and plan each individual step before starting
- ⚠ First bend and then cut ends to length
 - Gather all dimensions like minimum straight lengths, extra length for flaring, bending radius, tube lengths for bows, etc.

- Consider steps
- Plan for clamping

- Check bending equipment specifications for limitations

- Start with first elbow
- Leave tube-end longer if in doubt

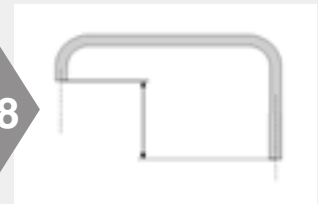
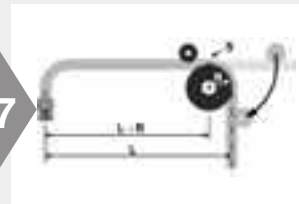
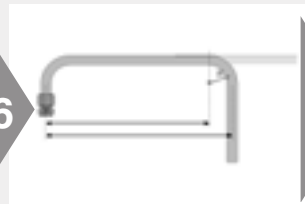
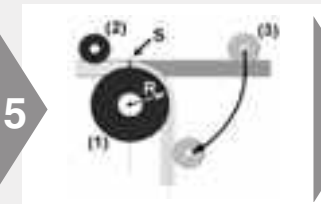

- ⚠ Mark start of bend on tube (S)
 - Adjust tube between bending roll (1), clamping roll (2) and pressure roll (3)
 - Bend tube by pulling lever

- Check bend angle
- Correct angle if necessary
- Gather all dimensions for next bending operation

- ⚠ Mark start of bend on tube
 - Continue bending
 - Check and correct each result before starting next bend

- After the last bend, check tube for angles and dimensions
- Now cut both tube-ends to correct length
- Make sure that tube fits without tension

F

Tube line fabrication guide for leak free systems

Every hydraulic, pneumatic and lubrication system requires some form of tube fabrication and fitting installation for completion. Proper fabrication and installation are essential for the overall efficiency, leak free performance, and general appearance of any system.

After sizing the tube lines and selecting the appropriate style of fitting, consider the following in the design of your system:

1. Accessibility of joints
2. Proper routing of lines
3. Adequate tube line supports
4. Available fabricating tools

- Keep tube lines away from components that require regular maintenance:

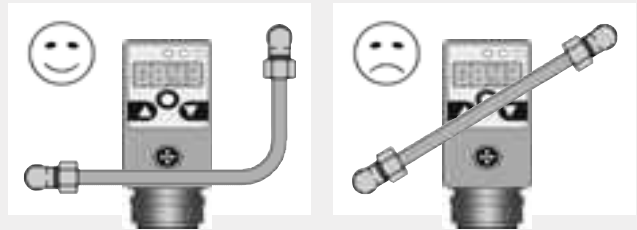

- Right-angled – parallel – clear
- Have a neat appearance and allow for easy trouble-shooting, maintenance and repair:

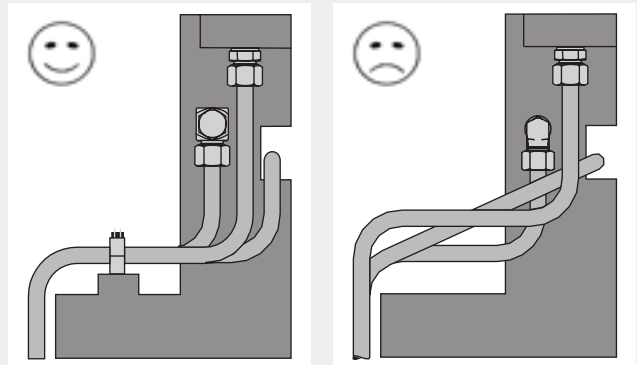

- Example for tube to hose connection:

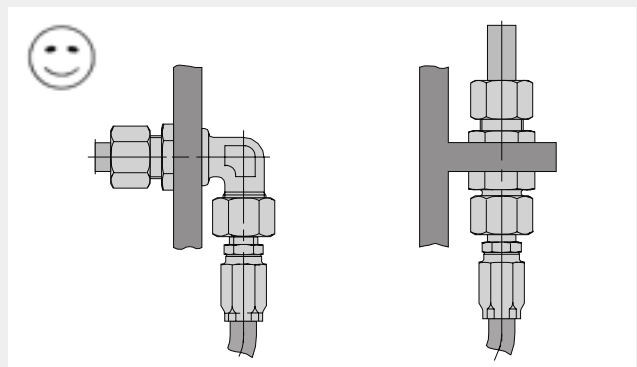

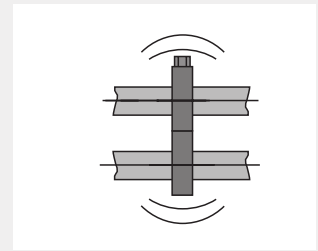
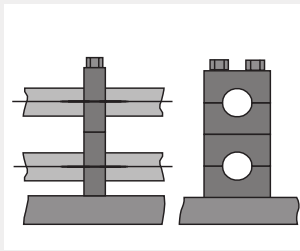

F

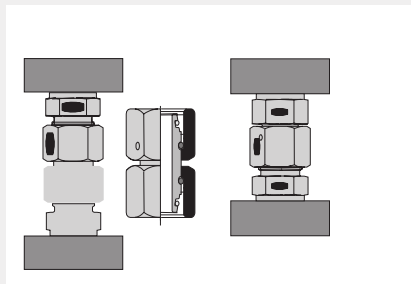
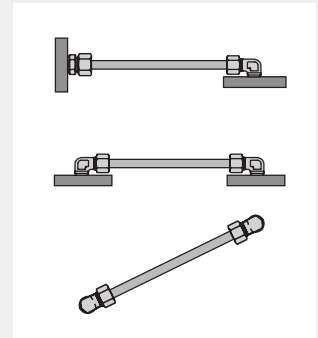
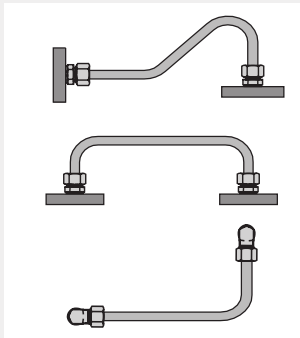

Tube line fabrication guide for leak free systems

● Support against actuating forces:

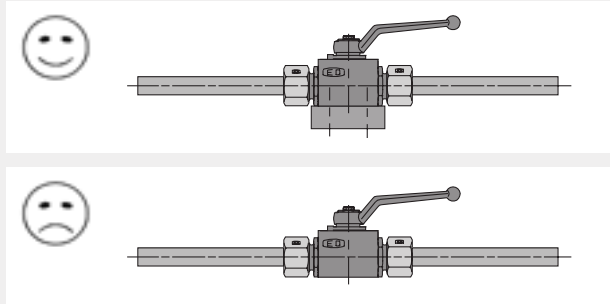

Recommended tools for tube line fabrication:

Cutting:

EO Tube cutting tool AV

EO Combined tube bending and cutting tool BAV

Tube cutters:

Steel: Type Kloskut;

Stainless Steel: Type 635 B-EX,

Type 218 B-SS Tru-Kut Sawing Vice

Deburring:

Parker deburring tool no. 226 DEBURR

Bending:

EO Combined tube bending and cutting tool BAV

EO Tube bending tool BV 6/18, BV 20/25

EO Tube bending tool BVP (programmable)

Tube lines have to be supported in certain distances:

Use sufficient tube clamps to support weight

Use sufficient tube clamps to protect joints from vibration

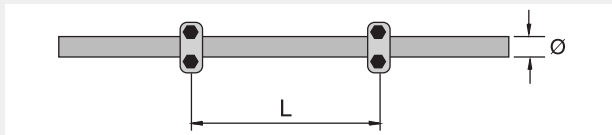

Ø [mm]	L [m]
6.0 – 12.7	1.0
12.7 – 22.0	1.2
22.0 – 32.0	1.5
32.0 – 38.0	2.0
38.0 – 57.0	2.7
57.0 – 75.0	3.0
75.0 – 76.1	3.5
76.1 – 88.9	3.7
88.9 – 102.0	4.0
102.0 – 114.0	4.5
114.0 – 168.0	5.0
168.0 – 219.0	6.0

Vibration has to be eliminated near by the connectors:

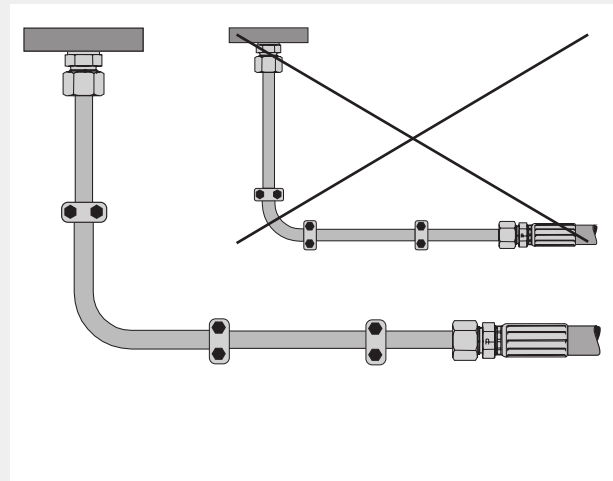

Allow expansion and contraction. Do not hamper expansion and contraction near by tube bends.

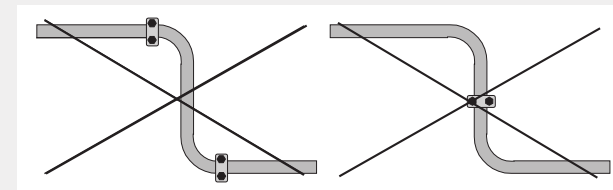
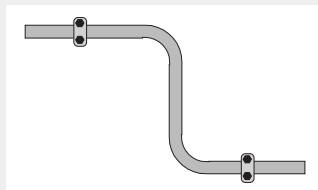



Contact Us

Tel: +44(0)191 549 7335

Email: hos@hos.co.uk

Web: www.hos.co.uk

