

Hydraulic & Offshore SUPPLIES

Parker Sensococontrol

Contact our team *and*
Order today on:
+44 (0)191 549 7335

Offshore House, Southwick Industrial Estate, Sunderland, SR5 3TX
hos@hos.co.uk | www.hos.co.uk



SensoControl[®]
Test Points
Diagnostic-
Test equipment
Industrial Products



Visual index

Series 1

Test point fitting with pin-lock

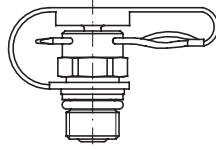

EMA1
p. Q4

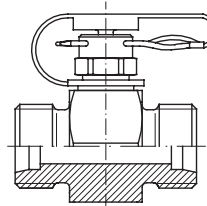

GMA1
p. Q5

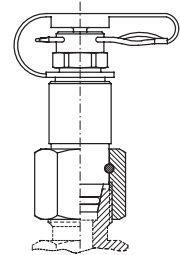

VKA1
p. Q6

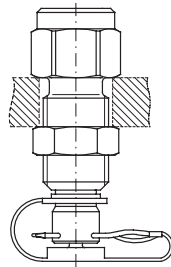

MAV ... MA1
p. Q7

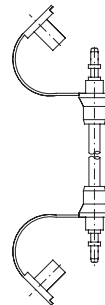

SMA1
P. Q7

Series 3

Test point with threaded connection
M 16x2

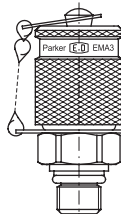

EMA3
p. Q8

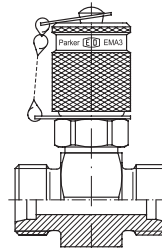

GMA3
p. Q9

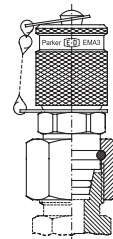

VKA3
p. Q10

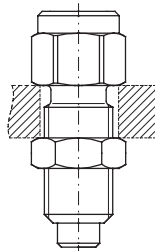

MAV ... MA3
p. Q11

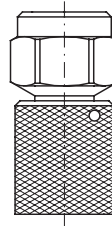

MAVMD ... MA3
p. Q11

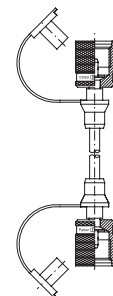

SMA3
p. Q11

SensoControl®

Product range

Diagnostic/Industrial



p. Q12

EMA1/EMA3-Test Point fitting

- For pressure monitoring and checking on high, low and negative pressure systems.
- For bleeding cylinders and hydraulic systems.
- For taking samples on high, low and negative pressure systems.

Advantages:

- Leakfree connection before valve is open
- Sturdy, safe constructions for small dimensions
- Easy handling
- Simple connection of measuring, control and switching devices
- Coupling under pressure up to 400 bar is possible with screw couplings
- Nominal pressures up to 630 bar
- Self locking metal guard cap, vibration resistant

Sealing system of the primary seal:

EMA1 by ball non-return valve.

EMA3 by cone seal with O-ring.

The new EMA3 sealing system guarantees minimum leakage rates.

The screw-on Cap (EMA3), and pin lock (EMA1) types both employ an O-ring seal as secondary sealing with the hose attached.

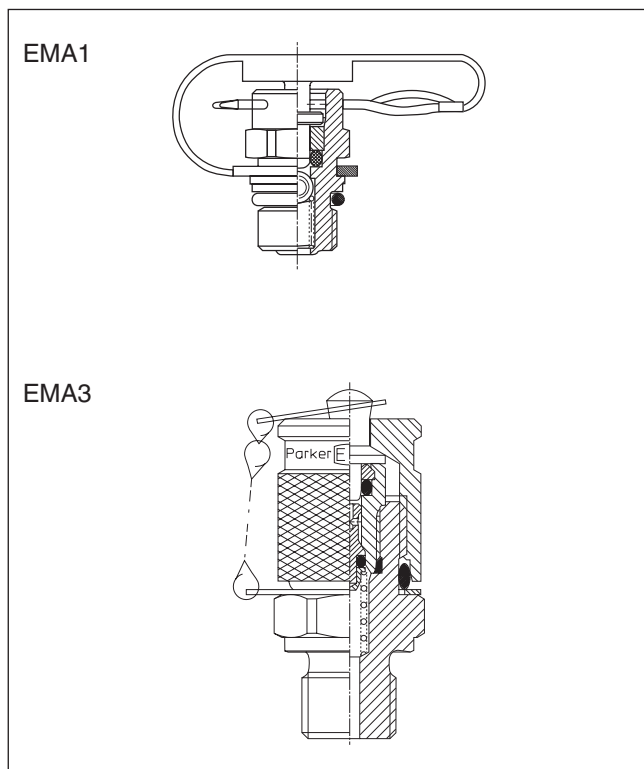

Differences between EMA1 and EMA3 types

- sealing system (see previous section)
- Test hose connection by plug-in coupling in EMA1
Test hose connection by threaded connection in EMA3
- Working pressures (see section advantages)

Working pressure

- EMA3 types up to 630 bar
- EMA1 types up to 400 bar
- Max. working pressure 630 bar for GMA, VKA and EMA... the recommended working pressure of fitting manufacturer has to be applied
- Joining under pressure up to 400 bar max.
- The allowable nominal pressures of each Test-Point are shown on the product pages.

Materials and Temperatures:

- Steel, zinc plated, Cr(VI)-free
- Stainless Steel, material 1.4571
- Seals:
 - FKM (Temperature range -20 to $+200^{\circ}\text{C}$)
 - EPDM Ethylene Propylene (for Break Fluid) (Temperature range -40 to $+150^{\circ}\text{C}$)
- Hose:
 - Polyamide (Temperature range: -35°C ... 100°C max.)
- Stainless Steel FKM only

Media:

- Suitable for hydraulic oils and other mineral oil based fluids (Please pay attention to the sealing materials used!)
- For use in conjunction with other liquid media please consult Parker

Approvals

DVGW for EMA3/8X1OR, EMA3/10X1OR, EMA3 1/8NPT, EMA 3/4 NPT

Perbunan = registered trademark of Bayer

EMA1 Test point fitting with pin-lock

Series 1

Male stud thread: BSP, metric

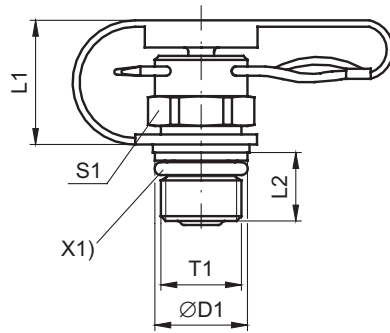

Fig. A

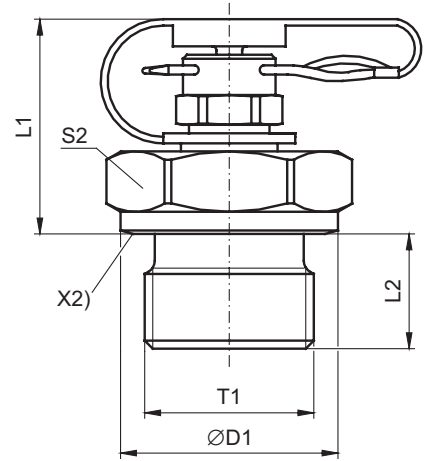

Fig. B

X1) O-ring
X2) Cutting face

T1	D1	L1	L2	S1	S2	Fig.	Weight g/1 piece	Order code*	PN (bar) ¹⁾ CF	DF**
M12×1.5	17.0	32.0	12.0		19	B	53	EMA1/12X1.5	400	4
M14×1.5	19.0	32.0	12.0		19	B	56	EMA1/14X1.5	400	4
M16×1.5	21.0	25.0	12.0		22	B	47	EMA1/16X1.5	400	4
G1/8	14.0	32.5	8.0		17	B	41	EMA1/1/8	400	4
G1/4	18.0	32.0	12.0		19	B	54	EMA1/1/4	400	4
G3/8	22.0	27.5	12.0		22	B	55	EMA1/3/8	400	4
G1/2	26.0	27.5	14.0		27	B	78	EMA1/1/2	400	4
M8×1	9.5	17.5	8.4	12		A	16	EMA1/8X1OR	400	4
M10×1	11.5	18.0	8.0	12		A	18	EMA1/10X1OR	400	4
M10×1	14.0	32.5	8.0		17	B	42	EMA1/10X1	400	4

**DF = Design Factor

1) Pressure shown = item deliverable

$$\frac{PN \text{ (bar)}}{10} = PN \text{ (MPa)}$$

*Please add the **suffixes** below according to the material/surface required.

Order code suffixes			
Material	Suffix surface and material	Example	Standard sealing material (no additional suffix needed)
Steel, zinc plated, Cr(VI)-free	CF	EMA1/12X1.5CF	NBR

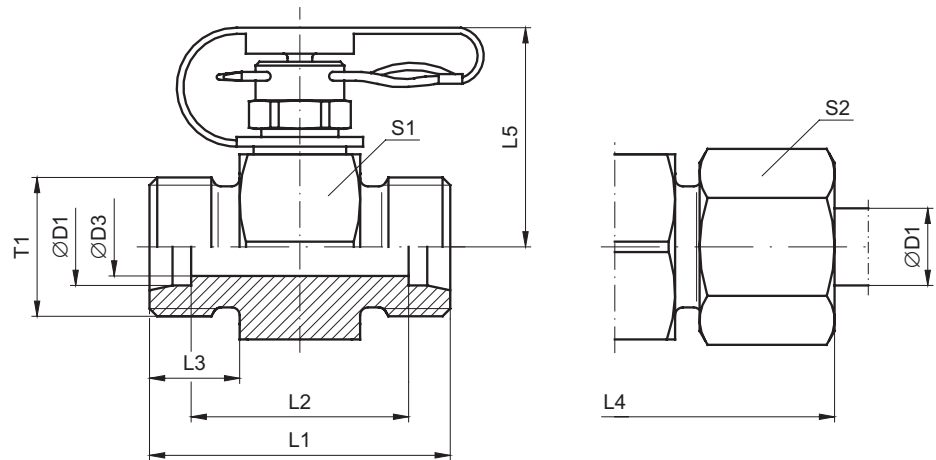

Series	D1	T1	D3	L1	L2	L3	L4	L5	S1	S2	Weight g/1 piece	Order code*	PN (bar) ¹⁾ CF	DF**
L ³⁾	06	M12×1.5	4	35	21	10	51	29.0	24	14	73	GMA1/06LOMD	315	4
	08	M14×1.5	6	35	21	10	51	29.0	24	17	75	GMA1/08LOMD	315	4
	10	M16×1.5	7	37	23	11	53	29.0	24	19	80	GMA1/10LOMD	315	4
	12	M18×1.5	8	37	23	11	53	30.5	24	22	96	GMA1/12LOMD	315	4
	15	M22×1.5	11	39	25	12	55	32.0	30	27	121	GMA1/15LOMD	315	4
	18	M26×1.5	14	39	24	12	57	33.0	32	32	139	GMA1/18LOMD	315	4
	22	M30×2	18	43	28	14	61	35.0	36	36	171	GMA1/22LOMD	160	4
S ⁴⁾	06	M14×1.5	4	39	25	12	55	29.0	24	17	82	GMA1/06SOMD	400	4
	08	M16×1.5	5	39	25	12	55	29.0	24	19	88	GMA1/08SOMD	400	4
	10	M18×1.5	7	39	24	12	57	29.0	24	22	90	GMA1/10SOMD	400	4
	12	M20×1.5	7	39	24	12	57	29.0	24	24	96	GMA1/12SOMD	400	4
	14	M22×1.5	10	43	27	14	63	30.5	27	27	121	GMA1/14SOMD	400	4
	16	M24×1.5	11	43	26	14	63	32.0	30	30	138	GMA1/16SOMD	400	4
	20	M30×2	15	47	26	16	69	35.0	36	36	222	GMA1/20SOMD	400	4

**DF = Design Factor

¹⁾ Pressure shown = item deliverable

³⁾ L = light series; ⁴⁾ S = heavy series

$$\frac{PN \text{ (bar)}}{10} = PN \text{ (MPa)}$$

Delivery without nut and ring. Information on ordering complete fittings or alternative sealing materials see page 17.

*Please add the **suffixes** below according to the material/surface required.

Order code suffixes			
Material	Suffix surface and material	Example	Standard sealing material (no additional suffix needed)
Steel, zinc plated, Cr(VI)-free	CF	GMA1/06LOMDCF	NBR



VKA1 Test point fitting with pin lock for cones

Series 1

With 24° cone swivel nut connection

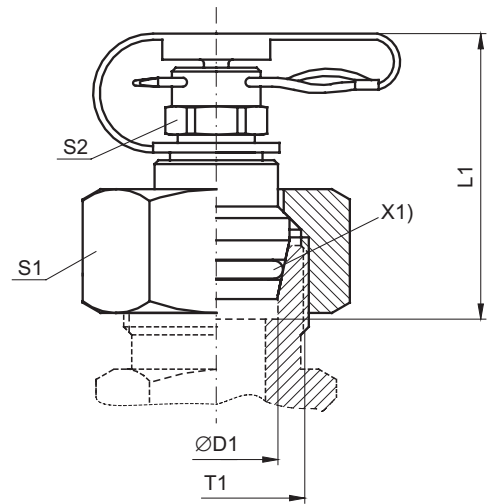
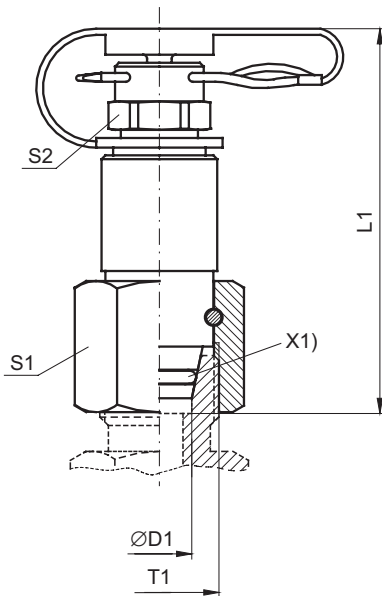

X1) O-ring

Series	D1	T1	L1	S1	S2	Fig.	Weight g/1 piece	Order code*	PN (bar) ¹⁾ CF	DF**
L ³⁾	06	M12×1.5	48	14	12	A	44	VKA1/06L	315	4
	08	M14×1.5	49	17	12	A	54	VKA1/08L	315	4
	10	M16×1.5	50	19	12	A	68	VKA1/10L	315	4
	12	M18×1.5	51	22	12	A	81	VKA1/12L	315	4
	15	M22×1.5	39	27	12	B	82	VKA1/15L	315	4
	18	M26×1.5	38	32	12	B	112	VKA1/18L	315	4
S ⁴⁾	06	M14×1.5	48	17	12	A	51	VKA1/06S	400	4
	08	M16×1.5	50	19	12	A	62	VKA1/08S	400	4
	10	M18×1.5	50	22	12	A	78	VKA1/10S	400	4
	12	M20×1.5	51	24	12	A	100	VKA1/12S	400	4
	14	M22×1.5	39	27	12	B	88	VKA1/14S	400	4
	16	M24×1.5	37	30	12	B	105	VKA1/16S	400	4
	20	M30×2	44	36	12	B	174	VKA1/20S	400	4

**DF = Design Factor

¹⁾ Pressure shown = item deliverable

³⁾ L = light series; ⁴⁾ S = heavy series

$$\frac{PN \text{ (bar)}}{10} = PN \text{ (MPa)}$$

*Please add the **suffixes** below according to the material/surface required.

Order code suffixes			
Material	Suffix surface and material	Example	Standard sealing material (no additional suffix needed)
Steel, zinc plated, Cr(VI)-free	CF	VKA1/06LCF	NBR

**MAV-MA1
SMA1**

**Test Point pressure gauge connector with pin-lock
Test Point high pressure hose with pin-lock**

Series 1

Female thread: BSP
Sealing: sealing ring DIN 16258

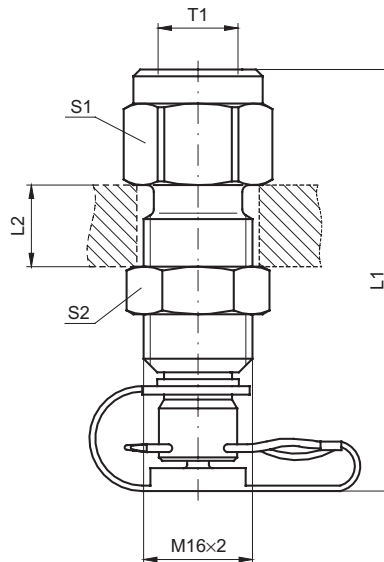

Pressure gauge connector: MAV-MA1

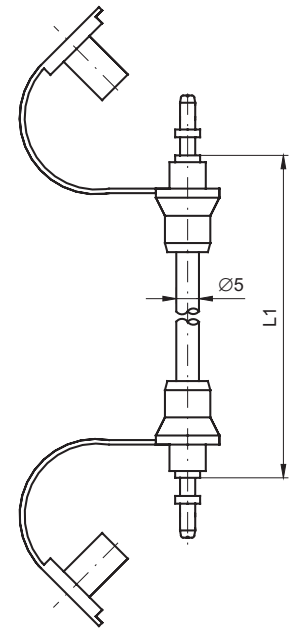

Test hose: SMA1

T1	L1	L2 max.	S1	S2	Weight g/1 piece	Order code*	PN (bar) ¹⁾ CF	DF**
G1/4	61.5	12	19	19	78	MAV1/4MA1	400	4.0
G1/2	72.0	12	27	19	135	MAV1/2MA1	400	4.0
	400.0				21	SMA1-400	400	2.5
	630.0				26	SMA1-630	400	2.5
	800.0				26	SMA1-800	400	2.5
	1000.0				31	SMA1-1000	400	2.5
	1500.0				40	SMA1-1500	400	2.5
	2000.0				49	SMA1-2000	400	2.5
	2500.0				58	SMA1-2500	400	2.5
	3200.0				70	SMA1-3200	400	2.5
	4000.0				84	SMA1-4000	400	2.5

**DF = Design Factor

¹⁾ Pressure shown = item deliverable

$$\frac{PN(\text{bar})}{10} = PN(\text{MPa})$$

*Please add the **suffixes**
below according to the material/
surface required.

Order code suffixes			
Material	Suffix surface and material	Example	Standard sealing material (no additional suffix needed)
Steel, zinc plated, Cr(VI)-free	CF	MAV1/4MA1CF	NBR

Note hoses with small diameter:

- Min. bending radius r = 20 mm
- Working temperature -20 °C up to 100 °C (short time to +120 °C)
- Hoses are to be protected from fire, from sharp-corners and hot objects.

For measuring with liquid pressure media please note:
Bleed before connecting tube! By capillary action discharge of the
pressure medium is prevented widely.

Temperature factor of pressure rating:

up to 0 °C	122 %
for 30 °C	110 %
for 50 °C	100 %
for 80 °C	86 %
for 100 °C	77 %



EMA3 Test Point with threaded connection M 16×2

Series 3

Male thread: BSP, metric

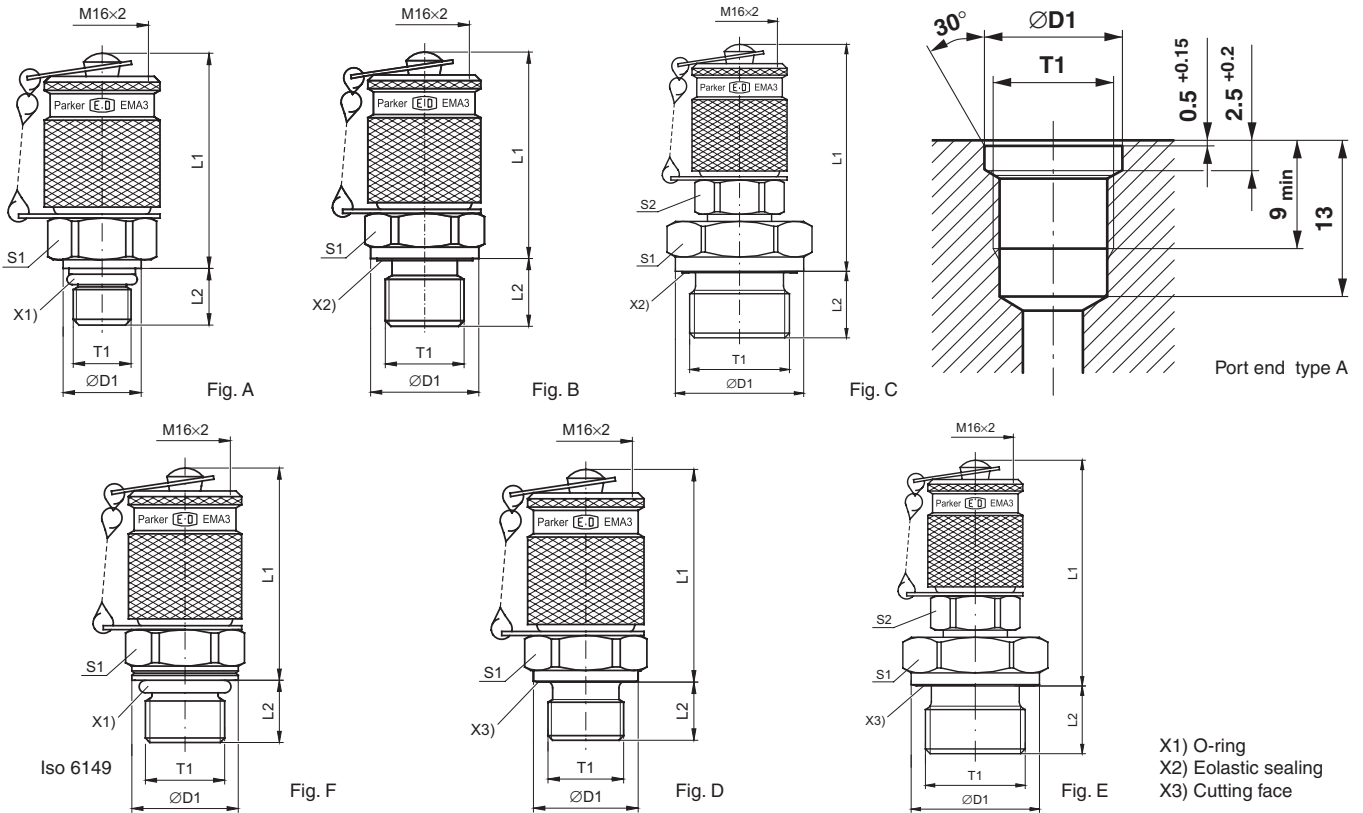

T1	D1	L1	L2	S1	S2	Fig.	Weight g/1 piece	Order code*	PN (bar) ¹⁾		DF**	
									CF	71	CF	71
M8×1	9.5	38.5	7.5	17		A	66	EMA3/8X1OR	250		4.0	
M10×1	11.5	37.0	7.5	17		A	70	EMA3/10X1OR	630	630	4.0	4
M14×1.5	18.8	39.5	11.0	19		F	79	EMA3/14X1.5ISO	630	630	4.0	4
M10×1	14.0	40.0	8.0	17		D	67	EMA3/10X1	400		4.0	
M12×1.5	17.0	38.0	12.0	17		D	74	EMA3/12X1.5	400		4.0	
M14×1.5	19.0	39.0	12.0	19		D	78	EMA3/14X1.5	400		4.0	
M16×1.5	21.0	40.0	12.0	22		D	90	EMA3/16X1.5	400		4.0	
G1/8	14.0	37.5	8.0	17		D	70	EMA3/1/8	400		4.0	
G1/4	18.0	39.0	12.0	19		D	77	EMA3/1/4	400		4.0	
G3/8	22.0	40.5	12.0	22		D	91	EMA3/3/8	400		4.0	
G1/2	26.0	46.0	14.0	27	17	E	137	EMA3/1/2	400		3.4	
G1/8	14.0	37.5	8.0	17		B	72	EMA3/1/8ED	400	400	4.0	4
G1/4	19.0	39.0	12.0	19		B	76	EMA3/1/4ED	630	630	4.0	4
G3/8	22.0	40.5	12.0	22		B	93	EMA3/3/8ED	630	630	4.0	4
M10×1	14.0	40.0	8.0	17		B	71	EMA3/10X1ED	400	400	4.0	4
M12×1.5	17.0	38.0	12.0	17		B	72	EMA3/12X1.5ED	630	630	4.0	4
M14×1.5	19.0	39.0	12.0	19		B	77	EMA3/14X1.5ED	400	400	4.0	4
G1/2	27.0	46.0	14.0	27	17	C	135	EMA3/1/2ED	400	400	4.0	4

**DF = Design Factor

1) Pressure shown = item deliverable

$$\frac{PN \text{ (bar)}}{10} = PN \text{ (MPa)}$$

*Please add the **suffixes** below according to the material/surface required.

Order code suffixes			
Material	Suffix surface and material	Example	Standard sealing material (no additional suffix needed)
Steel, zinc plated, Cr(VI)-free	CF	EMA3/10X10ORCF	NBR
Stainless Steel	71	EMA3/10X10OR71	VIT

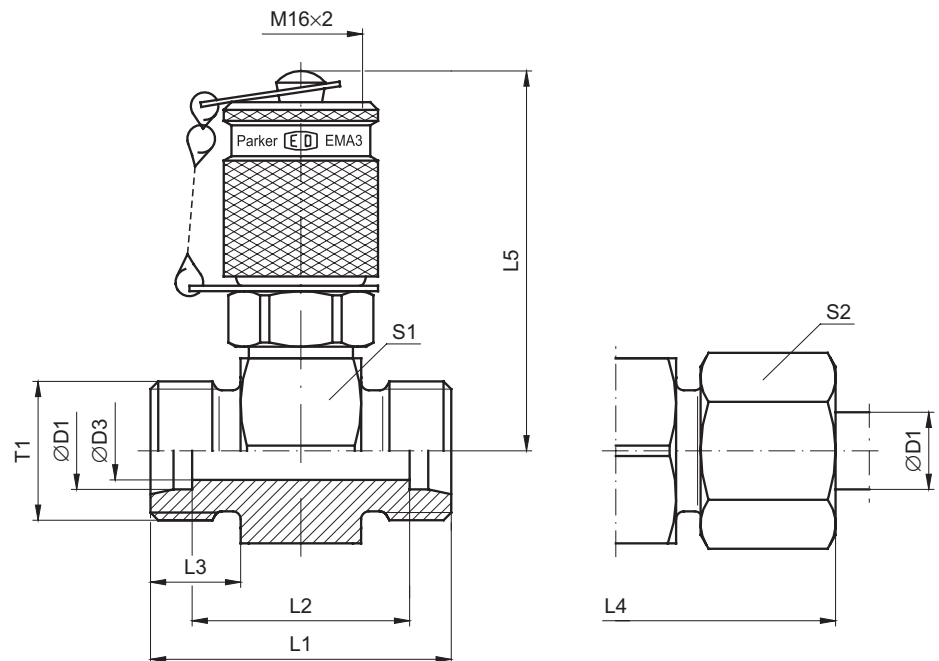

Series	D1	T1	D3	L1	L2	L3	L4	L5	S1	S2	Weight g/1 piece	Order code*	PN (bar) ¹⁾		DF**	
													CF	71	CF	71
L ³⁾	06	M12×1.5	4	35	21	10	51	49.0	24	14	126	GMA3/06LOMD	315	315	4	4
	08	M14×1.5	6	35	21	10	51	49.0	24	17	128	GMA3/08LOMD	315	315	4	4
	10	M16×1.5	7	37	23	11	53	49.0	24	19	132	GMA3/10LOMD	315	315	4	4
	12	M18×1.5	8	37	23	11	53	50.5	27	22	145	GMA3/12LOMD	315	315	4	4
	15	M22×1.5	11	39	25	12	55	52.0	30	27	174	GMA3/15LOMD	315	315	4	4
	18	M26×1.5	14	39	24	12	57	53.0	32	32	192	GMA3/18LOMD	315	315	4	4
	22	M30×2	18	43	28	14	61	55.0	36	36	220	GMA3/22LOMD	160	160	4	4
	28	M36×2	23	43	28	14	61	57.5	41	41	259	GMA3/28LOMD	160	160	4	4
	35	M45×2	30	47	26	16	69	60.0	46	50	363	GMA3/35LOMD	160	160	4	4
	42	M52×2	36	47	25	16	71	64.5	55	60	419	GMA3/42LOMD	160	160	4	4
S ⁴⁾	06	M14×1.5	4	39	25	12	55	49.0	24	17	137	GMA3/06SOMD	630	630	4	4
	08	M16×1.5	5	39	25	12	55	49.0	24	19	141	GMA3/08SOMD	630	630	4	4
	10	M18×1.5	7	39	24	12	57	49.0	24	22	141	GMA3/10SOMD	630	630	4	4
	12	M20×1.5	7	39	24	12	57	49.0	24	24	150	GMA3/12SOMD	630	630	4	4
	14	M22×1.5	10	43	27	14	63	50.5	27	27	172	GMA3/14SOMD	630	630	4	4
	16	M24×1.5	11	43	26	14	63	52.0	30	30	195	GMA3/16SOMD	400	400	4	4
	20	M30×2	15	47	26	16	69	55.0	36	36	254	GMA3/20SOMD	400	400	4	4
	25	M36×2	20	51	27	18	75	57.5	41	46	329	GMA3/25SOMD	400	400	4	4
	30	M42×2	25	55	28	20	81	60.0	46	50	412	GMA3/30SOMD	400	400	4	4
	38	M52×2	32	61	29	22	91	64.5	55	60	616	GMA3/38SOMD	315	315	4	4

**DF = Design Factor

¹⁾ Pressure shown = item deliverable

³⁾ L = light series; ⁴⁾ S = heavy series

$$\frac{\text{PN (bar)}}{10} = \text{PN (MPa)}$$

Delivery without nut and ring.

Information on ordering complete fittings or alternative sealing materials see page 17.

*Please add the suffixes below according to the material/surface required.

Order code suffixes			
Material	Suffix surface and material	Example	Standard sealing material (no additional suffix needed)
Steel, zinc plated, Cr(VI)-free	CF	GMA3/06LOMDCF	NBR
Stainless Steel	71	GMA3/06LOMD71	VIT



VKA3 Test Point for cones with threaded connection M 16×2

Series 3

With 24° cone swivel nut connection

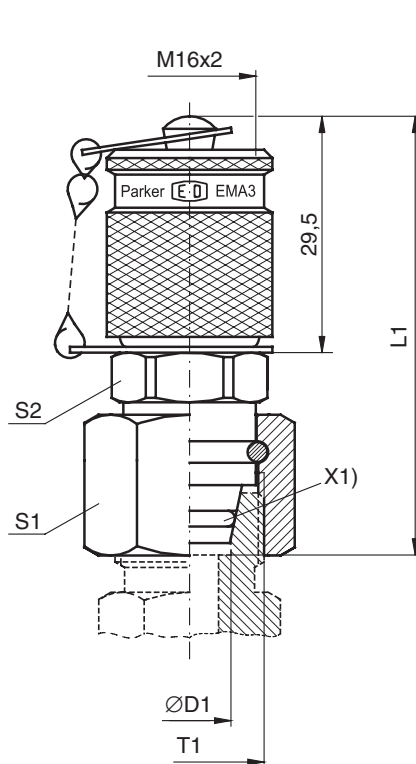

Fig. A

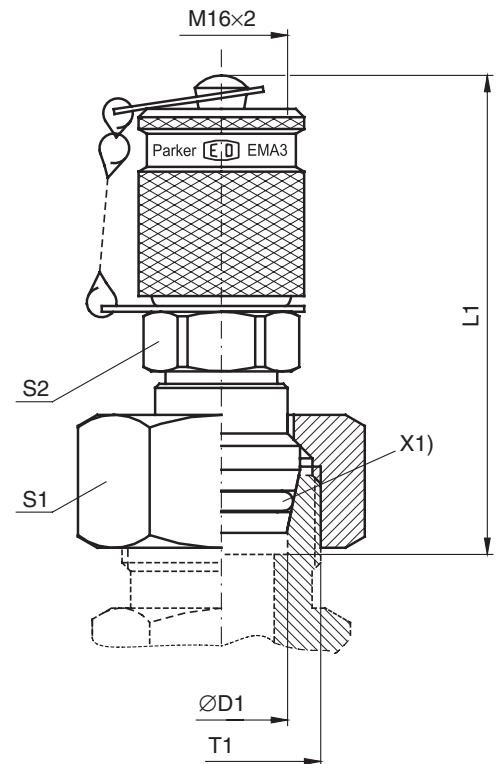

Fig. B

X1) O-ring

Series	D1	T1	L1	S1	S2	Fig.	Weight g/1 piece	Order code*	PN (bar) ¹⁾		DF**	
									CF	71	CF	71
L ³⁾	06	M12×1.5	55	14	17	A	82	VKA3/06L	315	315	4	4
	08	M14×1.5	51	17	17	A	82	VKA3/08L	315	315	4	4
	10	M16×1.5	53	19	17	A	93	VKA3/10L	315	315	4	4
	12	M18×1.5	53	22	17	A	107	VKA3/12L	315	315	4	4
	15	M22×1.5	59	27	17	B	133	VKA3/15L	315	315	4	4
	18	M26×1.5	59	32	17	B	163	VKA3/18L	315	315	4	4
	22	M30×2	60	36	17	B	205	VKA3/22L	160	160	4	4
	28	M36×2	64	41	17	B	269	VKA3/28L	160	160	4	4
	35	M45×2	71	50	17	B	411	VKA3/35L	160	160	4	4
	42	M52×2	72	60	17	B	592	VKA3/42L	160	160	4	4
S ⁴⁾	06	M14×1.5	50	17	17	A	81	VKA3/06S	630	630	4	4
	08	M16×1.5	52	19	17	A	88	VKA3/08S	630	630	4	4
	10	M18×1.5	53	22	17	A	99	VKA3/10S	630	630	4	4
	12	M20×1.5	54	24	19	A	121	VKA3/12S	630	630	4	4
	14	M22×1.5	59	27	17	B	136	VKA3/14S	630	630	4	4
	16	M24×1.5	58	30	17	B	156	VKA3/16S	400	400	4	4
	20	M30×2	65	36	17	B	223	VKA3/20S	400	400	4	4
	25	M36×2	68	46	17	B	367	VKA3/25S	400	400	4	4
	30	M42×2	74	50	17	B	444	VKA3/30S	400	400	4	4
	38	M52×2	81	60	17	B	655	VKA3/38S	315	315	4	4

**DF = Design Factor

¹⁾ Pressure shown = item deliverable

³⁾ L = light series; ⁴⁾ S = heavy series

$\frac{PN(\text{bar})}{10} = PN(\text{MPa})$

*Please add the **suffixes** below according to the material/surface required.

Order code suffixes			
Material	Suffix surface and material	Example	Standard sealing material (no additional suffix needed)
Steel, zinc plated, Cr(VI)-free	CF	VKA3/06LCF	NBR
Stainless Steel	71	VKA3/06L71	VIT

MAV...MA3 Test point pressure gauge connector with threaded connection M 16×2
MAVMD...MA3 Test point with threaded connection M 16×2
SMA3 Test point high pressure hose with threaded connection M 16×2 W Series 3

Female thread: BSP
 Sealing: sealing ring DIN 16258*

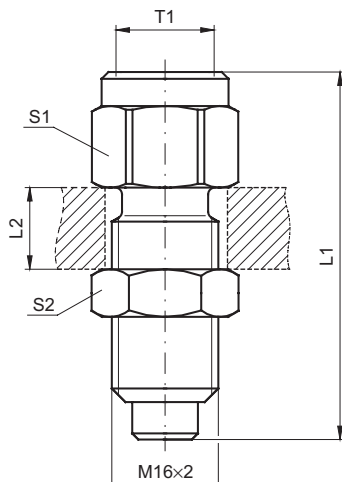

Pressure gauge connector:
MAV...MA3

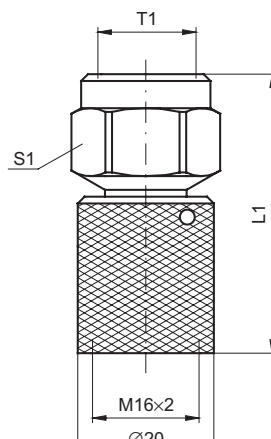

Gauge-Direct-Connector:
MAVMD...MA3

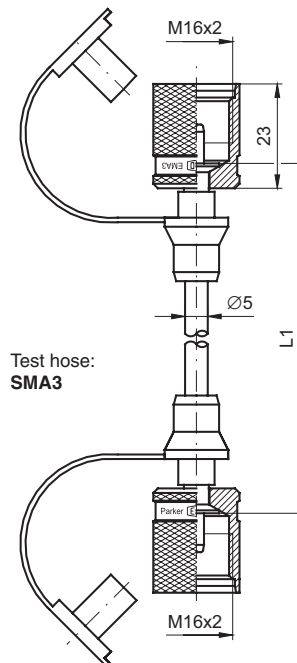

Test hose:
SMA3

T1	L1	L2 max.	S1	S2	Weight g/1 piece	Order code*	PN (bar) ¹⁾ CF	DF**
G1/4	54.0	12	19	19	74	MAV1/4MA3	630	4.0
G1/2	64.0	12	27	19	129	MAV1/2MA3	630	4.0
G1/4	41.0		19		61	MAVMD1/4MA3	630	4.0
G1/2	51.5		27		103	MAVMD1/2MA3	630	4.0
	200.0				73	SMA3-200	630	2.5
	300.0				74	SMA3-300	630	2.5
	400.0				74	SMA3-400	630	2.5
	630.0				79	SMA3-630	630	2.5
	800.0				83	SMA3-800	630	2.5
	1000.0				87	SMA3-1000	630	2.5
	1500.0				95	SMA3-1500	630	2.5
	2000.0				105	SMA3-2000	630	2.5
	2500.0				110	SMA3-2500	630	2.5
	3200.0				125	SMA3-3200	630	2.5
	4000.0				137	SMA3-4000	630	2.5

**DF = Design Factor

¹⁾ Pressure shown = item deliverable

$$\frac{PN \text{ (bar)}}{10} = PN \text{ (MPa)}$$

*Please add the **suffixes** below according to the material/ surface required.

Order code suffixes			
Material	Suffix surface and material	Example	Standard sealing material (no additional suffix needed)
Steel, zinc plated, Cr(VI)-free	CF	MAV1/4MA3CF	NBR

* Sealing rings according to DIN 16258 for steel design of copper, for stainless steel design of stainless steel.

Note hoses with small diameter:

- Min. bending radius r = 20 mm
- Working temperature -20 °C up to 100 °C (short time to +120 °C)
- Hoses are to be protected from fire, from sharp-corners and hot objects.

For measuring with liquid pressure media please note:
 Bleed before connecting tube! By capillary action discharge of the pressure medium is prevented widely.

Temperature factor of pressure rating:

up to 0 °C	122 %
for 30 °C	110 %
for 50 °C	100 %
for 80 °C	86 %
for 100 °C	77 %



SensoControl®

ServiceJunior



The ServiceJunior makes possible the measurement and display of pressures with one instrument. Measured values are shown with high precision on a 4-digit display. Pressure peaks are securely captured at a scanning rate of 10 ms.

- Digital pressure measurement and display
- Back-lit measured value display
- Accuracy $\pm 0,5\%$ FS
- Pressure peaks captured by displaying MIN/MAX reading
- Graphic display with bar graph (trailing indicator), peak & hold function

ServiceJunior Kit

- Delivery in storage-case
- Incl. test point-adapters and test hoses

Catalogue 4054/UK

SensoControl®

ServiceJunior wireless



Utilising the ServiceJunior wireless from Parker's SensoControl family of products allows you to comfortably record the pressure values taken from one or several measurement points on your machine or installation. Stored measurement data is transmitted to a PC across distances of up to 50 meters.

- Measured data memory for storing pressure sequences
- Network operations: monitor several measurement points
- Read-out data from measured data memory to the PC via a radio interface
- Set and evaluate measurement data using PC software "JuniorWin"

Catalogue 4054/UK

SensoControl®

Serviceman



The Serviceman has 2 inputs for sensors. This enables a differential pressure measurement by pressing only one key. Fast comparisons of actual and set values are done very easily.

- Easily operation
- Prevention of measuring errors due to automatic sensor recognition
- Two-line display
- Pressure peak measuring in 2 msec.

Serviceman Kit

- Delivery in storage-case
- Incl. test point-adapters and test hoses
- Attachments and sensors to measure pressure/temperature, flow

Catalogue 4054/UK

SensoControl®

The Parker ServiceMaster "Easy"



Measurement and display of up to four measured values simultaneously. Proportional technology differential values, addition, performance and signals are very easily analysed.

- Rapid fault diagnosis = high quality maintenance
- Pressure spike measurement 1 msec
- Measured value storage to record pressure sequences with various storage functions (auto trigger, start-stop, etc)
- USB PC interface
- Setting and evaluation of measurement data with "SensoWin" software.

Bulletin 4057/UK

SensoControl®

The Parker ServiceMaster



The ServiceMaster is a multi-channel hand meter for the simultaneous measuring of important hydraulic values. All hydraulic parameters such as pressure, differential pressure, flow and hydraulic power can be measured, displayed, stored and processed.

- Fast malfunction diagnosis = high servicing quality
- Measured data memory for storing pressure sequences
- Set and evaluate measurement data using PC software "JuniorWin"



ServiceMaster Kit:

- Delivery in storage-case
- Incl. attachments
- test point-adapters and test hoses

Catalogue 4054/UK

Pressure sensor SCPT



- Pressure measuring range up to 1000 bar
- Accuracy $\pm 0,25\%$ FS

Catalogue 4054/UK

Hydraulic tester SCLV-PTQ



- Test of pressure and flow (pump-test)
- Integrated load-limiting device

Catalogue 4054/UK

Tachometer SCRPM



Temperature sensor SCT



- Oil temperatures up to 125°C
- Compatible with flow measurement turbine SCFT

Catalogue 4054/UK

Turbine flow meter type SCFT



- Pressure measuring range up to 750 l/min.
- Accuracy: 1% from measured value
- Pressure range up to 480 bar

Catalogue 4054/UK

- Measurement range up to 10,000 RPM
- Accuracy $\pm 0,5\%$ FS
- Easy and fast measurement

Catalogue 4054/UK

SensoControl® Controller Family



The Controllers are used in control, regulating and monitoring systems when switching or analogue signals, or a display, are required.

The Controllers can replace

- mechanical switches
- mechanical displays (manometers, thermometers, sight glasses)
- sensors

and combine all the functions of the above-mentioned components in one instrument.

- large display
- freely settable
- rugged metal design
- compact
- long-term stability
- reliable
- interference-free

Catalogue 4083/UK

SensoControl®

Pressure Controller SCPSD



Simple operation, comprehensive functionality and long working life are the major features of the electronic SCPSD PressureController.

Features:

- Bar/PSI/MPa
- compact design
- rotatable
- rugged housing (IP 67)
- simple operation
- 2 switching outputs
- 4 switching points
- settable analogue output
- time delay (damping)
- hysteresis/window function
- password

If pressure is to be displayed, or the requirement is for rapid switching or analogue signals, which can be set simply and without additional adjustments, then the SCPSD is the ideal solution.

Catalogue 4083/UK

SensoControl®

TemperatureController SCTSD



Simple operation and comprehensive functionality are the major features of the electronic SCTSD TemperatureController.

Features:

- °C and °F
- compact design
- rotatable
- rugged housing (IP 67)
- simple operation
- 2 switching outputs
- 4 switching points
- settable analogue output
- delay times (damping)
- hysteresis/window function
- password

If temperature is to be displayed, or the requirement is for temperature-dependent switching or analogue signals, which can be set simply and without additional adjustments, then the SCTSD is the ideal solution.

Catalogue 4083/UK

SensoControl®

LevelController SCLSD



Simple operation and comprehensive functionality are the major features of the electronic SCLSD LevelController.

- level display in mm/inch/%
- compact design
- rotatable
- rugged housing (IP 67)
- settable via menu
- high & low display
- switching output
- analogue output
- proven float measuring system
- simple operation
- flexible installation
- hysteresis/window function

The LevelController is very suitable for monitoring tank levels. With its menu-controlled setting of level switching points, a very wide range of applications can be conveniently carried out. If the percentage display is selected, the fullness level is shown to the operator in a consistent manner, independently of the tank shape.

Catalogue 4083/UK

SensoControl®

LevelTempController SCLTSD



Simple operation and comprehensive functionality are the major features of the electronic SCLTSD LevelTempController.

Features:

- temperature and level
- compact design
- rotatable
- rugged housing (IP67)
- simple operation
- menu-controlled setting
- probe
- locating bore
- switching output
- analogue output
- hysteresis/window function
- password

With the LevelTempController it is possible to set and display temperature and level separately on a common platform. It is precisely in the field of tank monitoring that the integration of level and temperature shows its unique potential.

Catalogue 4083/UK

SensoControl®

OilTankController SCOTC



The OilTankController offers standardised connection points for an air filter and a filler coupling, which are additional to the LevelTempController.

It is precisely in the field of tank monitoring for series production that the integration of level and temperature, in combination with the air filter and filler coupling, shows its unique potential. Only one location bore is required for all 4 functions.

- proven measuring system
- level and temperature display
- mm/inch/% displays
- high and low display
- only one bore
- continuous level measurement
- connections:
 - filler coupling
 - air filter
 - under-pressure
- no surge tube needed

Catalogue 4083/UK

SensoControl®

Pressure sensor SCP Mini



The SCP Mini pressure sensor was designed for industrial application needs and is used in control, regulating and monitoring systems, when the requirement is for rapid pressure-dependent analogue signals. The SCP Mini sensor is noted for its compact design, high linearity and excellent interference resistance.

- stainless steel cell
- small size
- high burst pressure
- resistant to pressure peaks
- shock and vibration resistant
- wide media compatibility
- high linearity
- long-term stability

Catalogue 4083/UK

SensoControl®

Pressure sensor SCP-EX



The SCP-EX pressure sensor was designed for the requirements of applications where there is a risk of explosion (II 2G EEx ia IIC T4) and is used in control, regulating and monitoring systems when there is a requirement for pressure-dependent analogue signals.

- rugged
- long-term stability
- reliable
- stainless steel
- EEx ia

Catalogue 4083/UK



SensoControl®

Pressur sensor SCP-Mobil



The SCP Mobil was especially developed for mobile hydraulic applications and can be modified to meet specific customer requirements.

- special electrical connections
- special output signals
- special protection measures
- measuring range from -1 ... +1 bar to 0 ... 4,000 bar

Catalogue 4083/UK

CanBus SCP

Pressure/Temperature Sensor with CANopen technology



Flexible, innovative and reliable

The new pressure/temperature sensor in the SCPT series offers flexible application possibilities in automation technology. Besides the pressure and temperature measurement combination, CANopen technology offers the designer cost-effective and reliable measuring technology.

Technical data:

- Pressure range (measuring range)
-1 ... 16 / 0 ... 60/150/400/600/1000 bar
- Temperature range (measuring range)
-25°C ... +105°C (± 2,0% FS max.)
- Accuracy ± 0,25% FS (typ.)
- Response time 1 ms
- Housing stainless steel 1.4404
- Sealing FKM
- Connections electrical M12 5-pin
hydraulic 1/2" BSP
- CANopen DS 301 v 4.1
Type 2.0 A
Profile DS 404 v 1.2
Functions LSS (DSS 305 v 2.0)

Advantages

- Combined pressure and temperature measurement
- Digital measured value capture and transmission
- Error monitoring/self-diagnosis
- Heartbeat function/SYNC

Applications

- Hydraulics/pneumatics
- Automation technology
- Paper machinery/automotive/mobile hydraulics

Leaflet 4059/UK

SensoControl®

Temperature sensors SCT



Compact design and high pressure resistance are the major features of the electronic TemperatureSensors.

Features:

- pressure resistant to 630 bar
- compact design
- stainless steel housing
- simple installation
- -50°C to 250°C
- 0/4 ... 20 mA

The SCT excels when temperature is being measured at higher pressures and compact size is required.

Catalogue 4083/UK

SensoControl®

Built-in instrument SCE-020



Ample connections, a flexible display and plenty of outputs are the major features of the SCE-020 display instrument.

Features:

- Inputs: Current
voltage
frequency
- units freely selectable
- adjustable display range
- outputs: switching output
analogue output
- serial interface: RS 232

If various measurement values are required to be shown simply and flexibly, then it is the SCE-020 display instrument that should be used.

Catalogue 4083/UK

Hydraulic & Offshore SUPPLIES



Offshore House, Southwick Industrial Estate, Sunderland, SR5 3TX
hos@hos.co.uk | www.hos.co.uk

